

# Operating Instructions

MTWD0Z5500

Wall-mounted ozone controller



**Shanghai Multiweal Environmental Technology Corp.,Ltd.**

Factory address: 2nd Floor, Building B, No. 458, Sizhuan Road, Sijing Town,

Songjiang District, Shanghai

Contact number: 021-60541080

Email: nicole\_hany@163.com

Shanghai Multiweal Environmental Technology Corp.,Ltd

## catalogue

I, To inform users .....	3
II. Product inspection .....	3
III. Instrument, Introduction .....	3
IV. Technical parameters .....	4
V. Installation mode of instruments and circulation groove .....	5
VI. Wiring label .....	6
VII. Key description .....	7
VIII. Measurement mode .....	8
IX. Browse mode .....	9
X. Calibration mode .....	10
1. Go to the calibration menu .....	10
2. Calibration interface description .....	10
3. Electrode calibration description .....	10
4. Electrode calibration process .....	11
XI. Set up the mode .....	13
1. Go to the Settings menu .....	13
2. Set up the menu key description .....	13
3. Description of the System Settings menu options .....	13
4. Parameter setting menu options description .....	14
5. Run the Settings menu option description .....	15
6. Set the default list of menu options .....	16
XII. Information Mode .....	18
XIII. Communication Agreement .....	18
1. Communication Introduction .....	18
2. data format .....	18
3. Floating whole register group (20 addresses ranging from 0 x 0000 to 0 x 0013) .....	20
4. Floating floating-point register group (20 addresses from 0 x 0000-0 ~	

0 x 0013) .....	22
5. Keep the register group (40 addresses from 0 x 0014 to 0 x 003 B) .	23
6. Control the transfer register group (with 20 addresses ranging from 0 x 0050 to 0 x 0063) .....	25
7. Information register group (20 addresses from 0 x 003 C to 0 x 004 F) .....	28
8. Communication control calibration .....	30
9. Communication parameter setting .....	32
10. Unit code table .....	33
XIV. Use and maintenance of electrodes .....	34
1. measuring principle .....	34
2. dead work .....	34
3. Calibration of the electrodes .....	34
4. Daily maintenance of the electrodes .....	35
5. technical parameter .....	35

4. Daily maintenance of the electrodes

Electrodes should be cleaned regularly and recommended once a week. Flush the platinum detection end of the electrode with clear water, and then wipe the platinum ring of the electrode bright with a soft paper towel.

5. technical parameter

Measuring range: 0-20 mg/L

Measurement accuracy:  $\pm 5\%$ F.S

Allow temperature range: 0-50 ° C

Temperature sensor type: PT1000

Flow rate requirement: 20-40 L/h

## 八、 Electrode use and maintenance

### 1. measuring principle

This product is a constant voltage type pole spectrum sensor consisting of a platinum electrode with a reference electrode and a micro-cell measurement system with a polarization electrode. A stable potential potential is maintained at the polarized electrode extreme, where different measured components produce different, linear well-behaved current strengths at the measured platinum electrode.

### 2. dead work

- ① Electrodes shall be damaged, clean and clean before normal use.
  - ② Connecting the electrode, the ozone electrode is greatly affected by the flow speed and flow rate, and needs to work in the circulation channel environment.
  - ③ Remove the electrode front protective cap and rinse the electrode with distilled water.
  - ④ Wipe the platinum ring of the electrode with a soft paper towel to ensure the sensitivity of the electrode, and do not wipe the rest, so as to avoid electrostatic interference.
  - ⑤ Soak the electrodes in clean water for approximately 10 minutes to ensure the liquid junction conduction.
  - ⑥ Calibrate and measurement according to the instrument manual.
- Note: Soak the electrodes in clean water bodies to ensure their moisture. During electrode transport and storage, a small amount of KCL will overflow the electrode protective cap to form white crystals that can be washed directly with water.

### 3. Calibration of electrodes

The electrode needs to be calibrated when used as compared with the DPD colorimetric method to ensure the accuracy and effect of the measurement.

## I. Tell the user

Thank you for supporting your company. Please read the instructions in detail to help you use our products correctly.

## II. Product inspection

Carefully open the package, check the instrument for damage and complete accessories, if any abnormality, please contact the dealer or the company immediately.

In any event shall the instrument be removed by itself, and the Company is no longer responsible for the warranty.

## III. Instrument, brief introduction

- 128 \* 64 dot-matrix LCD display, switchable in Chinese and English, IP65 protection level, all-weather stable operation
- simple menu design, simple and convenient operation, graphical prompt, beautiful and clear interface
- software digital filtering is adjustable, with enhanced hardware resistance to interference, making measurements more stable and adapted to complex industrial environments
- global access power supply 85~260VAC, but also customized DC model 18 to 36 V D C
- RS-485 digital interface, MODBUS - RTU communication protocol, read and write two-way communication, can achieve remote complete control of the instrument

#### IV. technical parameter

ozone	measuring range	0.00~20 mg/L.00
	resolution ratio	0.01 mg/L
	Measurement accuracy (electronic unit)	±0.10 mg/L
temperature	measuring range	-10.0~130.0 °C
	resolution ratio	0.1 °C
	Measurement accuracy (electronic unit)	±0.3 °C
	Temperature input	PT1000
	temperature compensation	Automatic / manual
Transfer current	Output, type	Two roads of 4~20 mA (the corresponding range can be set)
	Current accuracy	±1% F.S
	output loading	less-than 500 Ω
control	Functional relay	One (which can be set to the cleaning or alarm function)
	Switch amount relay	2 SPST relays
	load capacity	2.5A 230VAC
data transmission	interface	All-way RS485 isolation voltage is 2500Vrms
	protocol	MODBUS-RTU (read-write two-way communication)
Other parameters	working power supply	85~260VAC or 18~36VDC (optional before order)
	working temperature	0~60°C
	Operating humidity	Relative humidity was <90%
	levels of protection	IP65
	way to install	Wall Mounting
	outline dimension	(H×W×D) 160×188×108 mm

#### 9. Unit code table

unit	Code hexagon	Code decimal	unit	Code hexagon	Code decimal
mV	0x00	0	ug/L	0x0D	13
nA	0x01	1	mg/L	0x0E	14
uA	0x02	2	g/L	0x0F	15
mA	0x03	3	ppb	0x10	16
Ω	0x04	4	ppm	0x11	17
KΩ	0x05	5	ppt	0x12	18
MΩ	0x06	6	%	0x13	19
uS/cm	0x07	7	mbar	0x14	20
mS/cm	0x08	8	bar	0x15	21
S/cm	0x09	9	mmHg	0x16	22
pH	0x0A	10			
°C	0x0B	11			
°F	0x0C	12			

## 8. Communication parameter setting

The contents in the instrument setting menu can be set through the communication function, they are located in the holding register group and the control transmission register group, the holding register group can be written with 0x06 function code, the control transmission register group can be written with 0x10 function code, and can refer to the corresponding subsection.

When setting these parameters, the instrument should be in the menu state of the setting mode. Therefore, in the measurement mode, the calibration mode code 0x0050 is first written to the working mode register (address 64) to enable the instrument to enter the setting mode.

If the password is not set (0000), the instrument goes directly to the Settings menu (Work event register (address 66) value is 1)

If the password is set (not 0000), the instrument displays the password data interface (working event register (address 66) value is 0). The password can be written in the working mode parameter register (address 65), and the password is correct to enter the setting menu.

Set the menu interface to write the following values to the working mode parameter register (address 65)

0x7FFF: The instrument resumes the factory operation

0x7FFE: The instrument performs the restart operation

## V. Installation mode of instrument and circulation tank

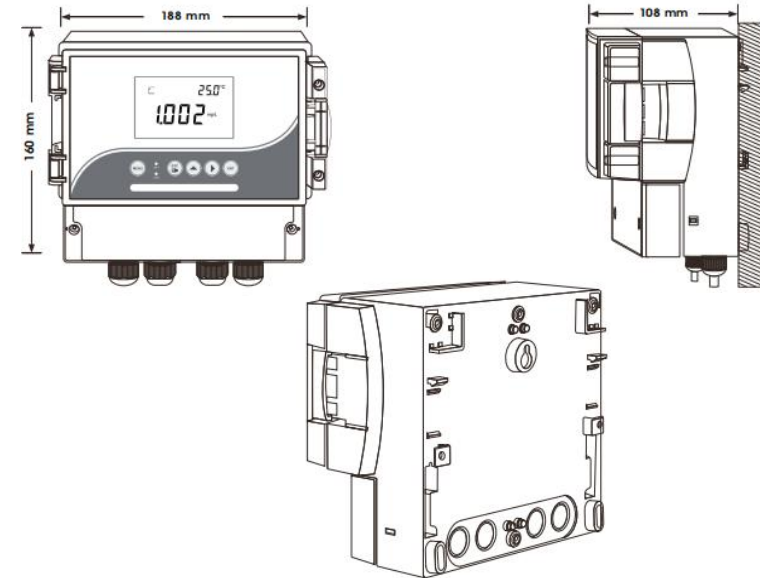

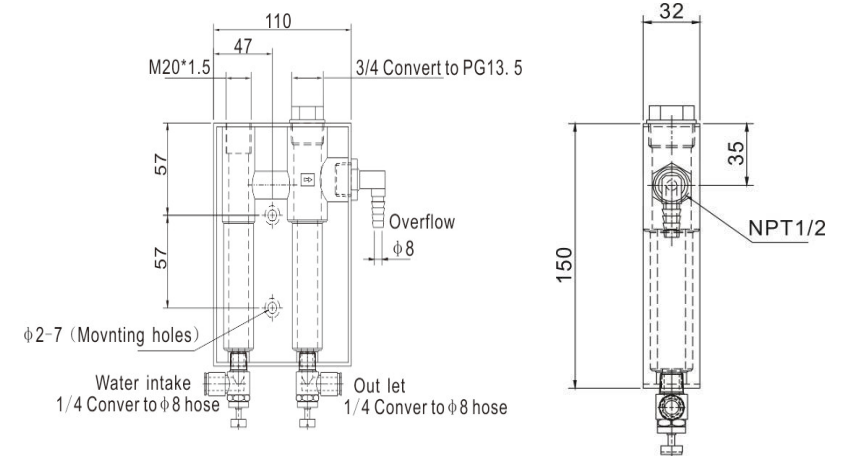

1. Install the opening size 92.5×92.5mm (positive tolerance)

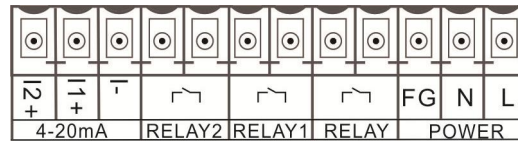
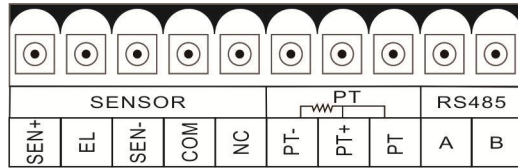

2. It is recommended to use 0.5 to 1 square wire, through the middle waterproof harness head, with a certain length margin.

## 一、Terminal label



binding post	function	binding post	function
SEN+	The ozone electrode is positive	RELAYF	Functional Relay (cleaning / alarm)
EL	polarized electrode	RELAY1	electric relay 1
SEN-	reference electrode	RELAY2	electric relay 2
COM	Signal ground	I1-	4~20mA channel 1, negative
NC	not connected	I1+	4~20mA channel 1, positive
PT-	PT1000 negative terminal	I2-	4~20mA channel 2, negative
PT+	PT1000 positive terminal	I2+	4~20mA channel 2, positive
PD	PT1000 drive		Power grounding line
A	RS-485 Communication T / R +	N	Power zero line
B	RS-485 Communication T / R -	L	Power line

Note: This wiring diagram is illustrated with 220V AC, if the user customized 24V DC, please pay attention to the indication label of the power supply on the meter

times the standard solution concentration value, for example, at a concentration of 5.00 mg/L, with the code of 500 (0x01F4).

For zero-point calibration, the standard liquid code is 1 (0x0001) (binary bit BIT0).

Calibration follows the rule of first calibration slope, and the electrode calibration case register (address 25) is 0x0002 (binary BIT1 is positioned). After continuing successfully calibrated zero, the electrode calibration case register is 0x0003 (binary BIT0 is also placed).

To clear the calibration data, write to the standard fluid code 0x7FFF.

## 7. Communication Control Calibration

### ① Calibrate step instructions

Users can use the communication function to control the instrument and complete the electrode calibration operation. Please read the Calibration Mode section for the electrode calibration rules. Communication calibration steps are as follows.

#### □ step 1:

Place the electrodes in the buffer or standard solution.

#### □ step 2:

Under the measurement mode or calibration menu, write the standard liquid code calibrate the state register (address 67), or the electrode calibration case register (address 25), to initiate the calibration.

#### □ step 3:

Read the calibration state register (address 67) to determine the current calibration status, and the register value and calibration status are as follows,

0x0000: Calibrated successfully (calibration menu returned)

0x0001: Calibration (Calibration status register is rereadable later)

0x0002: Wrong buffer (returned to calibration menu)

0x0003: Calibration measurement signal stabilized for long time (180 seconds) (calibration menu returned)

0x0004: Electrode slope or zero-point offset out of range (Calibration menu returned)





0x0005: Wrong calibration order (calibration menu returned)

If the calibration is successful, repeat steps 2 and 3 to continue to calibrate the other points. Other errors were recalibrated by prompting for excluding errors. To return to the measurement mode, it is available at the working mode register (address 64) writes to the measurement mode code 0x0010. The electrode calibration, electrode zero point offset and slope can be viewed in the holding register group at any time.

### ② Standard liquid code

When calibrating the slope point, the standard solution code is 100

## 二、Keynote

key	Key function description
	<p>Press this key in measurement mode to enter browse mode to browse the measurement related values</p> <p>Browse to continue in browse mode until measurement mode</p> <p>Press this key in another mode to return the key</p>
	<p>Press this key in the measurement mode to enter the calibration mode</p> <p>Press this button to move the option up when the menu interface has the ▲ symbol</p> <p>This key is the value up key</p>
	<p>Press this key in measurement mode to enter the Settings menu</p> <p>Press this button to move down the option when the menu interface has the ▼ symbol</p> <p>This key is the value is set</p>
	<p>In measurement mode, this key enters the information mode and continue to view the set parameters and instrument information</p> <p>Press this ► button to switch with symbols on the menu interface to the next menu. This key is used as the numerical shift key when the value is set</p>
	<p>Press this key in browsing mode to lock the current browsing interface (prevent the browsing timeout from returning the measurement automatically)</p> <p>Press this key for confirmation in another mode</p>

### 三、 measurement pattern

Start the measurement mode, showing the main measurement parameters and instrument status. The interface shows the figure below.

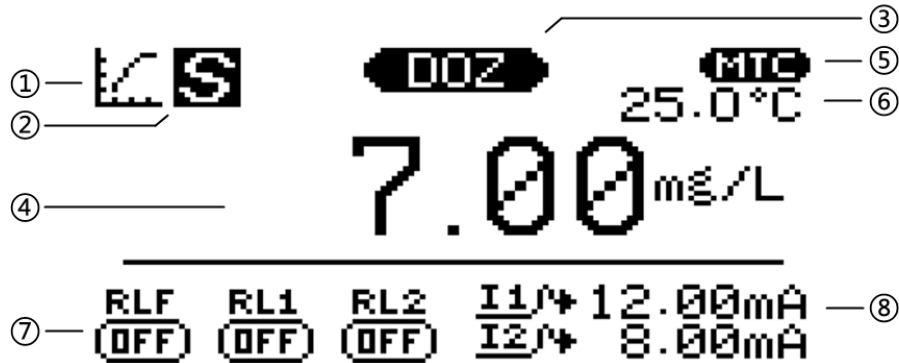

- ① Working mode indication, measurement mode.
- ② The main measurement stability symbol that indicates that the main measurement is stable.
- ③ Measure the value type. DOZ: ozone.
- ④ Measurement value display area. If OVER indicates the upper limit, UNDER indicates the upper limit.
- ⑤ Temperature measurement value type. MTC: Manual temperature compensation. ATC: Automatic temperature compensation.
- ⑥ Temperature measurement value display area. If OVER indicates the upper limit, UNDER indicates the upper limit.
- ⑦ Relay status.  
RLF: functional relay status, ON: closed. OFF: break.  
RL1: Relay 1 status, ON: closed. OFF: break.  
RL2: Relay 1 status, ON: closed. OFF: break.
- ⑧ Variant current value.  
I1: The output current value of the transmission current channel 1.  
I2: The output current value of the transmission current channel 2.

□ Address 65: Working mode parameters for some operations in instrument control, see specific application. Generally alternative keys, the correspondence is as follows, the values are defined in a 16 decimal mode.

0x0001: 0x0002: 0x0003: 0x0004: 0x0006:

□ Address 66: Work event, this register value reflects an event where the current instrument is in working mode, and the user generally does not need to care about it.

□ Address 67: Calibration status for electrode calibration operation, refer to the Communication Control Calibration Section.

□ Address 68, 69, 79, 71, 72, 73: Basic information of the instrument, and the values are defined in a 16 decimal mode.

## 6. Information register group (20 addresses from 0x003C~0x004F)

The information register contains the instrument running status and information, such as the version number, serial number, etc., and is read using the function code 0x03. You can also use the function code 0x06 to modify the relevant register value of the instrument operating status, and control the instrument for electrode calibration and other operations.

register	address hexadecimal	address decimal	name	type	attribute	remarks
keep register FC 0x 03 fetch FC 0x06 write in	0x 003C~0x	60~63				
	0x 0040	64	work pattern	inte	R/W	
	0x 0041	65	Working mode	inte	R/W	
	0x 0042	66	Work events	inte	R	
	0x 0043	67	Calibration status	inte	R/W	See also those
	0x 0044	68	Instrument type	inte	R	
	0x 0045	69	Instrument model	inte	R	
	0x 0046	70	software release	inte	R	
	0x 0047	71	Hardware version	inte	R	
	0x 0048	72	serial number	inte	R	
	0x 0049	73	serial number	inte	R	
	0x 004A~0x	74~79				

□ Address 64: Working mode. This register value reflects the current working mode of the instrument. The corresponding value of the working mode to the register can control the instrument to enter the corresponding mode. The corresponding relationship is as follows, and the value is defined in a 16 decimal mode.

0x0010: Measurement mode





0x0020: Information mode

0x0030: Browse mode

0x0050: Set the mode

0x0060: The calibration mode

## 四、Browse mode



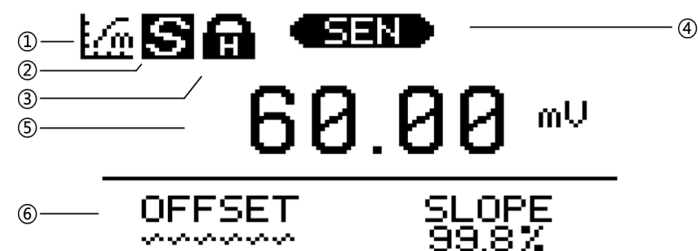

In the measurement mode, the key  enter the browsing mode. If there are multiple browsing pages, continue press  to browse in turn until the measurement mode is returned. The browsing mode mainly displays the electrode signal and the calibration situation and other parameters, as a supplement to the main display interface. One-minute no-button operation will automatically return to the measurement mode. If it needs a long time to view, you can press  lock the current interface, and then the key  can exit the lock. The interface is shown below.



- ① Working mode indicates, Browse mode.
- ② The main display area measures the stability symbol, indicating that the main display area value is stable.
- ③ Interface lock symbol, press ENT key in browsing mode to lock the current interface, to prevent the automatic return of measurement mode without operation.
- ④ Measurement value type in the main display area. SEN: The electrode signal.
- ⑤ Main display area measurements. If OVER indicates the upper limit, UNDER indicates the upper limit.
- ⑥ Electrode calibration information display area. OFFSET: Zero-point offset. SLOPE: Slope. Some values indicate that the corresponding point has been successfully calibrated. Wave lines indicate uncalibration or calibration failure.

## Calibration mode

### 1. Enter the calibration menu

Press  in the measurement mode to enter the electrode calibration menu and press  or  key to select the point to be calibrated, and press the key  to enter the calibration interface.

The last item in the calibration menu clear calibration data, which lets you clear calibrated information.

The calibration menu interface is operated without a button for a long time, and the instrument will automatically return to the measurement mode.

### 2. Calibrate interface instructions

The indicator icon of the calibration interface is , refer to the measurement mode and browse mode icons.

### 3. Specifications for electrode calibration

① Ozone electrodes can be calibrated for up to two points, and the uncalibrated electrodes must calibrate the slope first, otherwise an incorrect order will be indicated.

② Slope calibration was successful, and the meter calculated the electrode slope. represented by SLOPE, the allowed range is 30.0 to 999.9%. The standard liquid concentration value used to calibrate the slope should be greater than 0.10 mg/L.

③ Continue to calibrate the zero point, calibrate the successful instrument to calculate the electrode zero point offset, the allowable range-0.50~0.10mg/L. It is represented by the OFFSET.

④ Repeat calibration zero, the successful calibration recalculates the electrode zero offset, failure the original calibration data.

⑤ Repeat calibration slope, successful calibration clears all previous

the allowable range and minimum interval, please refer to 11.4 And eleven.5. Read and write was 100 times when controlled for ozone values, and 10 times when controlled for temperature values.

For example, when the device is controlled with ozone, read the register value of 1000, indicating 10.00mg/L, to set a value of 5.00 mg/L, the minimum interval corresponding to 500,4mA and 20mA is 2.00 mg/L.

□ Address 84,85: Two parameters of the functional relay. The value of the register is the integer type, and when the parameter 1 value is 0, the functional relay is the alarm mode. When the value of parameter 1 is 1~1000, the functional relay is cleaning mode, and the value of parameter 1 is cleaning interval in hours. The value of parameter 2 is in cleaning mode, indicating the cleaning duration, range1~1000, per seconds.

## 5. Control transfer register group (20 addresses from 0x0050~0x0063)

The relay switch value and the transmission current corresponding value set by the control transmission register for the user are read using the function code 0x03. When the instrument is in the setting menu interface (setting state), you must use the function code 0x10 to write the value of the two registers of one device at a time. For example, a closed value and a disconnected value of a relay. Of course, they are also continuous in the address. The address list is as follows. Property bar R is readable, W is writable, and D indicates factory recovery. This register is restored to the default value. Default reference 9.6, Set the default list of menu options.











register	address hexadecimal	address decimal system	name	type	attribute	remarks
control Change send register FC 0x 03 fetch	0x 0050	80	4~The corresponding value	inte	R/W/D	Function code 0x 10 is written
	0x 0051	81	4~Corresponding values	inte	R/W/D	
	0x 0052	82	4~Corresponding value of	inte	R/W/D	Function code 0x 10 is written
	0x 0053	83	4~Corresponding values	inte	R/W/D	
	0x 0054	84	Function relay parameter 1	inte	R/W/D	Function code 0x 10 is written
	0x 0055	85	Function Relay Parameter 2	inte	R/W/D	
	0x 0056	86	Relay 1 is turned-on value	inte	R/W/D	Function code 0x 10 is written
	0x 0057	87	Relay 1 turns-off the value	inte	R/W/D	
	0x 0058	88	Relay 2 is available at a	inte	R/W/D	Function code 0x 10 is written
0x 0059	89	Relay 2 turns off the value	inte	R/W/D		
	0x 005A~0x	90~99				

- address 80, 81: 4~The corresponding values of 20mA channels 1, 4mA and 20mA.
- address 82, 83: 4~Corresponding values for 20mA channels, 2, 4mA and 20mA.
- Address 86, 87: on and off value of relay 1.
- Address 88, 89: relay 2 on and off value.

When the above four devices read and write the value of their corresponding register, to judge the multiple relationship between the device correlation and

calibration information, recalculates SLOPE, and fails the original calibration data. 

## 4. The electrode calibration process

- ①  Enter the calibration menu and put the electrode into the standard liquid. Without the calibrated electrode, select the slope option in the menu, and press the key    to enter the standard liquid concentration value input interface. Electrodes with calibrated slope can calibrate zero directly from the process.
- ② Use the value setting key    to set the current standard liquid concentration value at the standard liquid concentration value input interface. After setting, the key  will enter the calibration interface and start the calibration.
- ③ The calibration process is fully automatic calibration. After the measurement value is stabilized, the instrument shows the measurement value stability symbol , and the SLOPE is calculated. If the results meet the requirements, the calibration will be successful, otherwise the calibration failure is indicated. Success or not, will be returned to the calibration menu.
- ④ Calibration failure Check the electrode performance or standard fluid according to the error prompt and re-calibrated after excluding the problem. Successful calibration can continue to calibration zero according to subsequent procedures. If further calibration is unnecessary, press the key  returns the measurement.
- ⑤ Put the electrode into the zero value standard liquid, select the zero

point option in the menu, press the key  to enter the calibration interface, and start the calibration zero point.

- ⑥ The calibration process is the same, for fully automatic calibration, waiting for the measurement value to stabilize, calculate the OFFSET, prompt success or failure, return to the calibration menu. If it fails, the zero point can be recalibrated against the prompt.

- ⑦ After a successful calibration of two points, press the key  returns the measurement mode.

Note: When waiting for the measurement value to stabilize, if the user keys

, the instrument will skip the automatic stability judgment, and calculate the calibration result according to the current display value.

this register is set, the temperature set value of the next address 33. If set to 0 (manual), the register set value changes to 250 (25.0°C), and to 2 (automatic), the set point changes to 0 (0.0°C).

- 0: hand movement
- 2: Automatic PT1000s (default value)

□ Address 33: Temperature supplement setting value. When the temperature supplement type is manual, this register indicates manual temperature value and automatic, this register indicates temperature offset value. This register is a 10-fold value, for example, by reading a register value of 500, it represents 50.0°C. To set a value of -10.0°C, you should write a value of -100.

Manual temperature values are set up to -10.0~130.0°C, temperature offset value set to -10.0~10.0°C.

□ Address 34: Electrode deviation, See, eleven. 4. 2, This register value is 100 times the value, such as when reading this register value is 100.10mg/L, To set the value to be -0.05mg/L You need to write to -5. electrode Deviation value set range -0.10~0.10mg/L.

□ Address 45: Digital Filter, Set range 1~24, The default value is 12.

□ Address 46: Language, not affected by factory operations.

- 0: English
- 1: simplified Chinese

□ Address 47: The backlight mode.

- 0: Delay shutdown (default value)
- 1: always on

□ Address 50~54: Correlation, indicating the current device-controlled object. The values of the register represent different objects and refer to the floating floating register address list where the ozone value is object 0 and the temperature value is object 4.

For example, the address 51 register is 4~20mA channel 2 Correlation, with a register value of 4, then 4~20mA channel current value of 2, controlled by the temperature value.

corresponding relationship between the bit and the calibration point is shown in the following table. If the calibration point is calibrated, the value of the corresponding bit is 1, otherwise it is 0.

□

The 16-bit whole type	BIT15~BIT 2	BIT1	BIT0
Calibration	No use	The slope point	null point

□ The addresses 26, 27 together constitute the electrode bias data (zero point offset), the electrode successfully calibrates the zero points, and the instrument calculates the electrode bias.

Take the electrode bias data as an example, the address 26 is the integer value, the address 27 high bytes indicate the decimal places, and the low bytes indicate the data units. For example, the address 26 register value is 3, and the address 27 register value is 0x020E (two decimal places, in unit of mg/L), then the offset data is 0.03 mg/L.

□ Address 28: Electrode slope, electrode successfully calibrated slope point, instrument calculation of electrode slope. The slope defaults 1-bit decimal in percentage.

For example, with a register value of 1001, the slope data is 100.1%

□ Address 30: The local address during communication, the set range of 1~247, the default value is 1, not affected by resuming the factory operation.

□ Address 31: Communication wave rate, set range of 0~4. The corresponding relationship between register value and communication wave rate is as follows, which is not affected by the recovery of factory operation.

0:1200

1:2400

2:4800





3:9600 (Default value)

4:19200

□ Address 32: the temperature supplement type, the instrument has two types of temperature supplement, manual and automatic, where the automatic temperature supplement mode is PT1000, the corresponding relationship is as follows. After

## 五、Setup mode

1. Enter the Setup menu press  in the measurement mode. If the instrument does not set the password, directly enter the Settings menu. If the instrument sets the password, it will enter the password input interface and use its value



setting key    enter password, then key , password is correct, enter the Settings menu, otherwise the password is wrong.



2. Set up the menu button description

① The setting menu consists of three main menus, respectively, system setting, parameter setting, operation setting, under the main menu interface,

Press  Key, can switch between three main orders.





Press  key to return to the measurement mode.

Press   to move the  cursor in the menu.





Press  key, enter the  cursor option.

② After entering the option Key  to return to the previous level.

If the current interface selects the interface for the option, press

  move the  cursor, press  Key Confirmation Options.

If the current interface is a numerical setting interface, Set the value

using the value set key   , and press the  key confirms the value.

### 3. System Settings menu options description

① language

The menu displays the language, optional in Chinese or English.

② Backlight mode

Delay closing: there is key operation, backlight is lit, no key operation in one minute after lighting, backlight is off.

Chang Liang: The backlight is always kept on.

③ digital filtering

Digital filtering is performed by sliding weighted mean filtering and set range 1~24.

The larger the numerical setting, the more stable the data, but the slower the response, suitable for greater interference situations.

④ Change the password

When the password has no password set to 0000, measurement mode press SET to directly enter the Settings menu.

The password is set to other values, the measurement mode press SET key to enter the password input interface, the password input is correct, to enter the settings menu.

⑤ Restore the factory

Performing the recovery factory operation, the instrument will clear the calibration information, restore some set parameters to the factory default value, and then restart the instrument.

### 4. Parameter Settings menu options description

① temperature compensation

Manual: If the instrument is not connected to the PT1000 temperature resistance, select this option and continue setting the temperature according to the range of -10.0 to 130.0°C.

Automatic: If the instrument is connected to the PT1000 temperature resistance, you can choose this option, when the instrument prompts to set the temperature offset, first do not adjust the value, directly press Confirm key is that the offset is set to 0.0°C. In actual use, if the

### Keep register group (40 addresses from 0 x 0014 to 0 x 003 B)

Keep the register for the user settings and electrode calibration information. Read the register value using the function code 0x03, when the instrument is in the setting menu interface 0 x 03 (in the setting state), write the register value using the function code 0x06, which of course must have writable properties to be allowed to write values. The address list is as follows. Property bar R is readable, W is writable, and D indicates factory recovery. This register is restored to the default value.

regist	address	address	name	type	attrib	remarks
keep er FC 0X03 fetch FC 0X06 write in	0x0014~0x0018	20~24				
	0x0019	25	Electrode	inte	R/D	Binary bit
	0x001A	26	Electrode	inte	R/D	
	0x001B	27	Electrode bias in	inte	R/D	
	0x001C	28	Electropole slope	inte	R/D	A decimal place,
	0x001D	29				
	0x001E	30	postal address	inte	R/W	See, eleven.5.1
	0x001F	31	Communication	inte	R/W	See, eleven.5.2
	0x0020	32	Temperature fill	inte	R/W/D	See, eleven.4.1
	0x0021	33	Temperature	inte	R/W/D	See, eleven.4.1
	0x0022~0x0026	34~38				
	0x0027	39	electrode	inte	R/W/D	See, eleven.4.2
	0x0023~0x002C	40~44				
	0x002D	45	digital filtering	inte	R/W/D	See, eleven.3.3
	0x002E	46	language	inte	R/W	See, eleven.3.1
	0x002F	47	Backlight mode	inte	R/W/D	See, eleven.3.2
0x0030~0x0031	48~49					
0x0032	50	4~20mA channel 1	inte	R/D	See, eleven.5.5	
0x0033	51	4~20mA channel 2	inte	R/D	See, eleven.5.5	
0x0034	52	Functional Relay	inte	R/D	See, eleven.5.3	
0x0035	53	Relay 1	inte	R/D	See, eleven.5.4	
0x0036	54	Relay 2	inte	R/D	See, eleven.5.4	
0x0037~0x003B	55~59					

□ Address 25: Calibration situation register, indicating the calibration point status by binary bit. The register is a 16-bit integer type, and the

The 16-bit whole	BIT15~BIT 3	BIT2	BIT1	BIT0
Relay status	No use	relay 2	relay 1	Functional

#### 4. Floating floating-point register group (20 addresses from 0 x 0000 to 0 x 0013)

Floating floating point register is floating point data for the measurement value and transmission current value of the meter. Access using function code 0x03 with address list below. The tribute bar R indicates readable and W is writable.

One data in the table occupies two register addresses, and when reading the data, two register addresses need to be read at a time to form a floating-point data.

regist er	address hexadeci mal	addres s decima	name	scope	explain	attr ibut e	remarks
float Floati ng point type regist er	0x0000	0	Ozone value	0.00~20.00	Float point mg/L	R	Over the upper limit of 20.01
	0x0001	1					
	0x0002	2	ozone sensor signal	-1.00~60.00	Floating point type	R	Over the upper limit of 60.01
	0x0003	3					
	0x0004	4					
	0x0005	5					
	0x0006	6					
	0x0007	7					
	0x0008	8	temperature scale ①	-10.0~130.0	Floating point type	R	Over the upper limit of 130.1
	0x0009	9					
FC 0X03 fetch	0x000A	10					
	0x000B	11					
	0x000C	12					
	0x000D	13					
	0x000E	14	4~20mA channel 1 current value	4.00~20.00	Floating point type	R	Over the upper limit of 21.00
	0x000F	15					
	0x0010	16	4~20mA channel 2 current value	4.00~20.00	Floating point type	R	Over the upper limit of 21.00
	0x0011	17					
	0x0012	18					
	0x0013	19					

① When the temperature compensation is set to automatic, this register is a temperature measurement and set for the user if set to manual.

temperature deviation between the instrument display temperature and the measured object is found is large, such as the instrument display temperature is 26.0°C and the mercury thermometer is 30.0°C, you can enter the temperature compensation option again, select the automatic option, the instrument prompt to set the temperature offset, and set the value to + 4.0°C, press Confirm the key confirmation. Returning to the measurement mode shows the temperature display value becomes 30.0°C, or the measurement value is 26.0°C plus offset set value of 4.0°C. The offset value allows to set a range of -10.0 to + 10.0°C.

#### ② electrode deviation

If the uncalibrated electrode has a large deviation in the zero value environment, set the corrected zero point and then be calibrated. The calibrated electrodes set this value and clear all the calibration information. Deviation allows setting the range -0.10~0.10mg/L.

5. Run the settings menu options description

① postal address

Native address during RS485 MODBUS communication. Set the range of 1~247.

② Communication Porter rate

RS485 MODBUS communication rate, optional 1200, 2400, 4800, 9600, 19200.

③ Functional relay

The function relay can be set to the alarm mode or the cleaning mode.

Alarm mode: suitable for external alarm device, relay 1 and relay 2 either closed, the functional relay closed.

Cleaning mode: suitable for external cleaning equipment, first set cleaning interval, set range of 1~1000 hours, then set cleaning duration, set range of 1~1000 seconds.

④ Relays 1 and relay 2

Relays are associated with ozone measurements.

The two relays are set in the same way. After entering the relay option, you need to set an on value and then a off value. The two values are set the same as the ozone measurement range, and the on and off values cannot be the same. The set range is 0.00~20.00mg/L

⑤ 4~20mA channel

4~2 Output current values of the 20mA channel 1 and ozone Measurements correlated.

4~The 20mA channel 2 output current value and temperature measurement Value correlation.

two4~20mAThe channel is set in the same way, entering 4~20mA channel After the option, set the corresponding value of 4mA and then 20mA. The set range of the two values is the same as the relevant measurement range, and the minimum interval between the two values is 200 words, as follows:

The set range for both values of channel 1 is 0.00~20.00mg/L, with a minimum interval of 2.00 mg/L.

The setting range of both values of channel 2 ranges from-10.0 to 130.0°C, with a minimum interval of 20.0°C.

er FC 0X04 fetch							lower limit of 8,000
	0x0002	2	Sensor signal value	-100~6000	integer	R	Over the upper limit of 7FFF
	0x0003	3	Sensor signal value decimal number and unit		integer	R	Over the lower limit of 8,000
	0x0004	4					
	0x0005	5					
	0x0006	6					
	0x0007	7					
	0x0008	8	temperature scale ①	-100~1300	integer	R	Over the upper limit of 7FFF
	0x0009	9	Temperature value decimal number and unit		integer	R	Over the lower limit of 8,000
	0x000A	10					
	0x000B	11					
	0x000C	12					
	0x000D	13					
	0x000E	14	Channel 1 current value	400~2000	integer	R	Over the upper limit of 2,100
0x000F	15	Channel 1 current value decimal number and unit		integer	R	Ultra-low r limit 370	
0x0010	16	Channel 2 current value	400~2000	integer	R	Over the upper limit of 2,100	
0x0011	17	Channel 2 current value decimal number and unit		integer	R	Ultra-low r limit 370	
0x0012	18	Relay status		integer	R	binary bit	
0x0013	19						

① When the temperature compensation is set to automatic, this register is a temperature measurement and set for the user if set to manual.

② Relay status register represents the relay status in binary mode, the register value is 16-bit integer, the BIT0 means the B I T 0, BIT1 indicates the relay 1 state, and BIT2 indicates the relay 2 state. Position value is 1, the relay is on and 0, the relay is off. The following table shows.

reply in the following format.

From the machine	FC +0x80	error code	CRC verification
1 byte	1 byte	1 byte	2 byte

⑤ Error code description:

- 0x01: Wrong function code, and received an unsupported function code.
- 0x02: Wrong register address and wrong register address to be accessed.
- 0x03: Wrong number of registers and registers to access are out of range.
- 0x04: The modified value is beyond the register value.
- 0x05: Verification error, and the CRC check value is incorrect.
- 0x06: Write error, the target register does not support the write operation.

3. Floating whole register group (20 addresses from 0x0000~0x0013)

The floating integer register is the integer data of the measurement value and the transmission current value of the instrument. Access using function code 0x04, the address list is listed below. The tribute bar R indicates readable and W is writable.

A measurement in the table consists of two parts, values in part, decimal and units in part.

For example, the address 0x0000 register is in the integer form of ozone value, the address 0x0001 register is decimal number and unit of ozone value, where high byte value is used to represent decimal number, low byte value means unit, obtained by query unit control table. If the 0x0000 register value is 0x02BC (decimal 700), 0x0001 register value is 0x020E, where 02 indicates 2 decimal places and 0E means unit mg/L, the current ozone value is 7.00 mg/L.

register	address hexadecimal	addresses decimal	name	scope	type	attribute	remarks
float integer register	0x0000	0	Ozone value	0~2000	integer	R	Over the upper limit of 7FFF Over the
	0x0001	1	Ozone value decimal number and unit		integer	R	

6. Set the menu options default list

If the value in the table is affected by the recovery factory operation, perform the recovery factory operation, and this option becomes the default value. It will not change otherwise.

menu	option	Windows default	Whether to recover Impact of ex-factory operation
System Settings	language	the Chinese language	no
	Backlight mode	Delay closed	yes
	digital filtering	12	yes
	Change the password	0000 (No password)	no
parameter setting	temperature compensation	Automatic temperature compensation, with a temperature offset of 0.0°C	yes
	electrode deviation	.000mg/L	yes
Run settings	ID address	1	no
	Communication Porter	9600	no
	Functional relay	Cleaning function, 1 hour interval	yes
	electric relay 1	The turn-on value is 0.00 mg/L The turn-off value is 20.00mg/L	yes
	electric relay 2	The turn-on value is 0.00 mg/L The turn-off value is 20.00mg/L	yes
	4~20mA channel 1	The 4mA value corresponds to 0.00 mg/L The 20mA corresponding value is 20.00mg/L	yes
	4~20mA channel 2	4mA corresponding value-10.0°C The corresponding value of 20mA is 130.0°C	yes

## 六、informative pattern

In the measurement mode, the  key can enter the information mode, which can browse the instrument setting parameter value and instrument information, with the current page and total page number prompts at the top right of the display interface, such as 1 / 7, the current first page, a total of 7 pages, and has

 Symbol prompt can press  Key page to browse.

The key  can return to the measurement mode. If there is no key operation for a long time, the instrument automatically returns to the measurement mode.

## 七、communicating protocol

### 1. Newsletter profile

The instrument adopts the RS485 hardware interface Modbus-RTU communication protocol. Data format N, 8, 1, that is, no parity, data 8 bits, stop bit 1 bit. The factory default native address is 1, and the baud rate is 9600. The address can be set in the range of 1 to 247, and the port rate is optional at 1200, 2400, 4800, 9600, 19200, which the user can set itself based on demand.

### 2. data format

The function codes used in the communication include 0x 03, 0x 04, 0x 06 and 0x10. Here is only a brief introduction of the corresponding data frame format of the function code used. If you know more, you can query the Modbus-RTU related information by yourself.

One register in the data accounts for two bytes.

The floating-point numbers are represented by two registers, namely 4 bytes.

The integer data is represented by a register with high bytes before, low bytes after, and negative numbers in complement form, x FFFF 0, -1.

① Function codes 0x03 and 0x04, read register content, the same instruction format for different register groups.

Host instruction format

From the	FC	Read the starting address	Number of number of read	CRC
1 byte	1 byte	2 byte	2 byte	2 byte

Next-bit machine reply format

From the	FC	Returns the total number	N register data	CRC
1 byte	1 byte	1 byte	N*2 byte	2 byte

② Function code 0x06 modifies a register value.

Host instruction format

From the	FC	Change the address of the	modified value	CRC
1 byte	1 byte	2 byte	2 byte	2 byte

Next-bit machine reply format

From the	FC	Change the address of the	Modified values	CRC
1 byte	1 byte	2 byte	2 byte	2 byte

③ The function code 0x10 modifies the multiple consecutive register values, the instrument can only be used to modify the two consecutive register values, and only a few fixed registers can be modified.

Upper computer command format, here to modify two registers for example, N=2 in the table below.

slave address	FC	revise The register start address	revise The register Number of N	modified value Bytes occupied by N * 2	first register modified value	the second register modified value	CRC verification
1 byte	1 byte	2 byte	2 byte	1 byte	2 byte	2 byte	2 byte

Next-bit machine reply format

From the	FC	Change the address of	The number of modified	CRC
1 byte	1 byte	2 byte	2 byte	2 byte

④ Error response, the next machine receives an error instruction, and will